

# Unify OpenScape Alarm Response

## Atos Unify OpenScape Alarm Response Economy OScAR-Eco V4

OpenScape Alarm Response - when every second counts.

The alarm server OScAR-Eco V4R1 is extremely versatile in its application, be it in hospitals or retirement homes, in the industrial sector or public administration, as well as in many other areas.

### Powerful alarm server

The requirements imposed today on alarm servers for emergency, breakdown, alarm, and crisis communication are highly diverse in terms of the interfaces and user devices that are employed as well as the complexity of the tasks and the number of concurrent voice communication channels.

To cover this need, Unify offers two different versions of the OScAR-Eco V4R1 alarm server:

#### OScAR-Eco 100

OScAR-Eco 100 is a small, but powerful alarm server for simple alarm tasks. It is a table-top solution that offers primarily:

- 4 to 8 channels for <sup>1</sup>VoIP
- 1 or 3 serial ports (RS232/RS422)
- Max. 1x ESPA-X
- Contact I/O: 16x IN, 8x OUT + 1x special OUT

#### OScAR-Eco 200

OScAR-Eco 200 is a 19"/1U alarm server for rack installation and features mainly the following expansions:

- 4 to 30 channels for ISDN or VoIP
- 2 serial ports (RS232/RS422)



OScAR-Eco V4R1 as OScAR-Eco 100 and OScAR-Eco 200

- Max. 5x ESPA-X
- Contact I/O: max. 32/64x IN, 16x OUT + 1x special OUT

### Most important functions

#### Connectivity options

Connectivity to:

- Nearly all communication systems - additional features only possible in conjunction with OpenScape platforms.
- Carrier networks
- Soft switches - VoIP unencrypted or encrypted

#### Broadcasts

Flexible broadcast strategies in multitasking operation with priority

control (100 or up to 1,000<sup>1</sup> broadcast groups)

- Launch broadcasts via contact inputs (with/without short-circuit and line-break detection), from control panels, over the phone, via e-mail or host systems (serially via ESPA4.4.4/TAP or through the LAN via ESPA-X)

#### Conferences

- Emergency conferencing with subscribers called by the system
- Phone-meeting-points with independent dial-in by subscribers

#### OScAR Satellites

Support of remote OScAR Satellite systems detached via LAN, with contact I/O and serial I/O

1. only OScAR-Eco 200

## Alerting/notifications

Alerting/notifications by:

- Phone calls
- OAP messaging
- E-mail
- Contact outputs with attached acoustic or light signalers

## Announcements

200 or up to 1,000<sup>1</sup> voice announcements from WAV files or recorded over the phone

## Administration

Hassle-free administration via browser. Available languages: German, English, French, Dutch, Turkish

## Logging

Detailed logging, revision-proof

## Security

Security mechanisms for customized tailoring to specific security requirements

## Cost effectiveness

- Particularly high availability and longevity
- Extremely low total cost of ownership (TCO)

## Typical areas of use

- Transmit nurse calls to mobile caregivers, with or without automatic callback to the calling patient, in combination with a nurse call system
- Forward error messages from production areas to mobile service technicians in combination with industrial controllers
- Emergency and distress calls in threat situations, assaults, fires or other incidents, with automatic emergency conferencing
- Silent fire alarms and error messages in combination with fire alarm systems
- Transmit technical alarms (e.g. when temperature or level too high, door open - also time-based) in combination with alarm detection systems or directly via contact inputs

- Manual activation of predefined alarm groups through customizable control panel
- Provision of a 24/7 conference dial-in node (chat room), e.g. for emergency conferences
- Service calls with spontaneous definition of how many responders are required
- Receive and forward deliberate and automatic alarms (e.g. no-movement alarms) raised over the phone, via emergency medallion or special emergency handset, e.g. Unify OpenStage M3 or OpenStage WL3

1. only OScaR-Eco 200

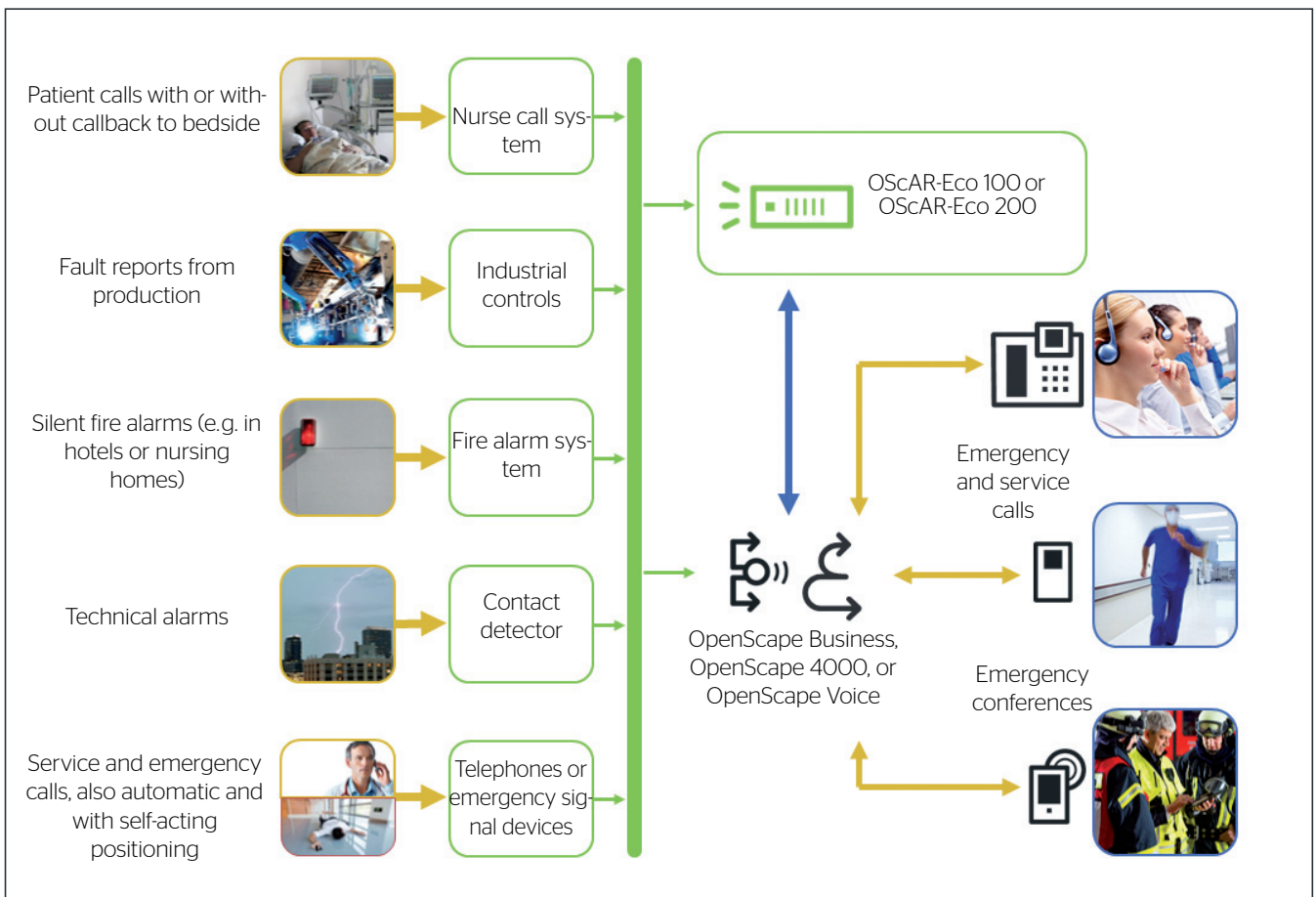

Typical areas of application for OScaR-Eco V4R1

# Hardware platforms

## OscAR-Eco 100

OscAR-Eco 100 is based on a highly compact alarm server hardware platform and comes in a table-top housing:

### Telephony channels

Up to 8 parallel telephony channels:

- VoIP (4 to 8 channels)

### Serial ports

- One serial port (RS232/RS422)
- 3 serial ports option

### Contact inputs/outputs

- 16 contact inputs with short-circuit and line-break detection
- 8 + 1 contact outputs



OscAR-Eco 100 - front view



OscAR-Eco 100 - rear view

## OscAR-Eco 200

OscAR-Eco 200 is based on the 19"/1U alarm server-hardware platform OscAR-200 designed for rack installation:

### Telephony channels

4 to 30 parallel telephony channels (VoIP or ISDN) realized in 3 versions:

- VoIP - 4 to 30 channels
- S<sub>2M</sub>/E1/T1 - 2 ports (only one usable)

### Serial ports

- 2 serial ports (RS232/RS422)

### Contact inputs/outputs

Contact inputs/outputs detached via USB; 8 top-hat rail modules, either:

- 8x IN and 2x OUT (= IOM-11A), or
- 4x IN (with short-circuit and line-break detection) and 2x OUT (= IOM-02A)

Mixed also possible.

### Further inputs and outputs

- Contact output (make-and-break contact), e.g. for last error message
- Connector for DCF77 receiver



OscAR-Eco 200 - front view



OscAR-Eco 200 - rear view



OscAR-Eco 200 - VoIP version



OscAR-Eco 200 - S<sub>2M</sub>/E1/T1 version

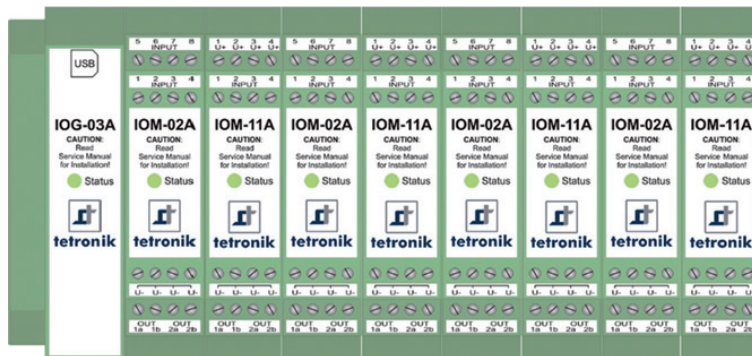

Contact I/O gateway with I/O modules, detached via USB

# Performance features

## Processes and process activation

### Standard broadcasts and broadcasts that automatically switch emergency conferences

Standard broadcasts and broadcasts that automatically switch emergency conferences can be activated by:

#### Phone or emergency handset

With Unify OpenStage M3 or Unify OpenStage WL3 for example:

- Through direct dialing or with voice messages for user guidance (German/English included as standard)
- Activation code (option)
- With option to record ad-hoc announcements and/or to specify ad-hoc how many subscribers must be reached

#### ESPA-X data interface (option)

- Activate an entire broadcast group or a call to any individual subscriber with variable info text
- Support of callback to phones, e.g. to a patient room (does not apply to TAP)

#### Serial data interface (option)

Via ESPA4.4.4 or TAP:

- Activation of a broadcast group with variable info text
- Support of callback to phones, e.g. to a patient room (does not apply to TAP)

#### Contact input (option)

- Activation of broadcast groups with customized voice announcements and text messages, used distinctly for normal activation or for short circuit or lead break
- Various activation modes (edge, state, toggle function)
- Customized alarm delays and activation periods

#### E-mail

Via e-mail over mail-to-phone<sup>1</sup> (option)

#### OscAR Satellite over ESPA-X coupling

From OscAR Satellite with contact inputs and serial interface over ESPA-X coupling<sup>1</sup> (option)

## Activating and attending phone-meeting-points

Activate and attend phone-meeting-points over the phone, using dial-in numbers. OscAR-Eco offers 10 process resources for 10 simultaneous communications processes (broadcasts/conferences), with priority control spanning all broadcasts. A specific number of these process resources can be reserved for high-priority processes (e.g. fire alarm).

## Broadcasts

OscAR-Eco supports up to 1,000 (OscAR-Eco 100: 100) individual broadcast groups, 100 of which are automatically included ex-works in the Basic Package.

Depending on their configuration, reached users/targets receive only audio info and/or text messages, or are connected to an audio conference.

Where needed, broadcast groups can be protected with a secret activation code. Broadcasts can also be configured to have high priority from the outset (e.g. for fire alarms). These broadcasts will interrupt all non-high priority processes for a maximum channel capacity.

## Addressing priorities

For every broadcast up to 25 targets can be defined in 3 different levels of addressing priority. OscAR supports different target types:

- Telephones (internal/external) that are called through the telephony channels
- E-mail recipients<sup>1</sup> (option)
- OpenStage WL3 cordless phones that are notified/alerted via OAP protocol with text messages

OscAR-Eco processes all targets that share the same addressing priority in parallel (e.g. OscAR-Eco calls all of these numbers simultaneously if sufficient resources are available), and those with different priorities sequentially.

Within the same level of priority the addressing sequence is random and OscAR-Eco either calls or does not call excess targets depending on the configuration. This means the priority during the call process can be placed either on a maximum processing speed or on a minimum disruption of staff.

If it detects a lack of resources, OscAR-Eco applies priority control spanning all broadcasts.

## Customizations for broadcast groups

For every broadcast group you can select from various customizations, e.g.:

### General

- Name/descriptor, identifier, activation code (option), and output of group-specific information
- Fixed number of users to reach and authorization to define this number ad hoc over the phone
- Contact output to activate

### Target-individual parameters

- Addressing priority and target type (see above)
- Time period, e.g. calling only during daytime (option), and security code (option)
- Reached criterion (e.g. manual confirmation required) and number of call attempts
- Dial-up alarm functions (if supported by PBX), such as speakerphone control, emergency call signaling, forced release, intrusion or call waiting/camp on

### Conference mode

Conference mode (yes/no) with details on the started conference plus, where needed, special optional settings for the right to speak and the announcement playback, e.g. for fire department conference.

### Various options

- High priority broadcast (yes/no)
- Security code required (yes/no, option)
- Calling of excess targets (yes/no)
- Audio-signaling and/or status info to the initiator (yes/no)

### Follow-up broadcasts

Follow-up broadcast(s) upon positive/negative final results, e.g. with the option of activating a follow-up broadcast (also re-start of same broadcast) whenever enough users were not reached. Not possible in conjunction with conference mode.

### Results e-mail (option)

Dispatch of results e-mail<sup>2</sup> with:

- Dispatch conditions (yes/no)
- E-mail address to specify

1. only OscAR-Eco 200

2. only OscAR-Eco 200

## Emergency conferences - phone-meeting-points

OScAR-Eco supports 10 different conferences.

Conferences can either be activated as an emergency conference by a broadcast (see above), or can be available as so-called phone-meeting-points or meet-me conferences for subscribers who dial-in themselves.

Note: An individual conference cannot be activated several times in parallel. The same also applies to broadcasts that utilize the same conference.

### Number of simultaneous conferences

The maximum number of simultaneous conferences is restricted by:

- The total number of available process resources (see above) - i.e. at least one process resource must be available to activate a broadcast with automatic switching of an emergency conference or a phone-meeting-point.
- License-related through the number of server channels - i.e. one conference is possible per 5 telephony channels.

### Customizations for conferences

For each conference you can customize, among other things:

- Name/descriptor, start ID and entry ID
- Announcements: start, entry, and calling
- Various max. durations and wait times
- Max. number of subscribers allowed to dial-in to the conference by themselves

### Process logging and system status messages

#### Time readouts

Time readouts are made:

- Usually NTP-synchronized
- In combination with a DCF77 radio clock receiver also DCF77 synchronized<sup>2</sup>

#### Processes

All activated processes, i.e. standard broadcasts, broadcasts with conference-switching and phone-meeting-points are logged and reported threefold including the date and time from start to end, overall results, broadcast- and conference-individual results, and activities during the conference:

- Syslog outputs sent directly to an external Syslog server
- Processes are printed out at the protocol printer (with buffering if the printer is temporarily unavailable)
- An e-mail with the results is sent to the person in charge<sup>2</sup> (option)

#### Storage

OScAR-Eco saves 1,500 process reports on the internal microSD card<sup>1</sup> or Compact-Flash card<sup>2</sup>, from where they can be retrieved, backed up or exported, and printed out any time over a browser.

The oldest logs are automatically overwritten when the memory is full. This occurs particularly when the logs are not exported from time to time, as is recommended.

### System status changes

Changes of the system status (e.g. interfaces that become active/inactive) are logged with the date and time via the protocol printer, via an external Syslog server in the LAN, and via the VCON virtual service console, and can also be reported through the contact outputs.

In addition, OScAR-Eco supports system status messages via SNMP traps. What is new is the support of SNMPv3 with confirmed traps, authentication of sent datasets, and encryption of the user data in the dataset.

### ESPA-X transparent mode option

The special ESPA-X transparent mode offers host systems, e.g. logistics systems in hotels or hospitals, the capability of calling telephones (normally mobile phones) and be called from these phones, and to communicate with the users by using freely editable text dialogs, i.e. with service staff.

This is of particular interest in combination with DECT phones on an OpenScape Cordless Enterprise (OpenScape 4000) or with WiFi-based handsets e.g. OpenStage WL3 in combination with OAP.

1. only OScAR-Eco 100



## Service functions

The VCON service console is a powerful and user-friendly configuration tool for service technicians that makes available a wide range of different service functions.

### Languages

- User interface: German, English
- Outputs: English

### Network settings for initial startup

Network settings for OScAR-Eco for link-up to host systems:

- IP address, network mask, and gateway of OScAR-Eco
- Access control to OScAR-Eco (whitelist entries)

These settings are made over the USB service interface.

### Configuration of individual services

- Configuration of PBX interfaces
- Configuration of NTP servers, WSG server, Syslog server, LAN printer and SNMP manager
- Carry out the basic digital I/O installation

- Configuration of ESPA4.4.4/TAP interface(s)
- Configuration of ESPA-X-interface(s)
- Save and restore service data and the entire microSD card<sup>1</sup> or CompactFlash card<sup>2</sup> including programs, licenses, service and user details, and logs
- Activate/deactivate, edit, and delete VCON reports
- Set the date and time
- Activate various traces
- Software downloads and license management
- Certificate management

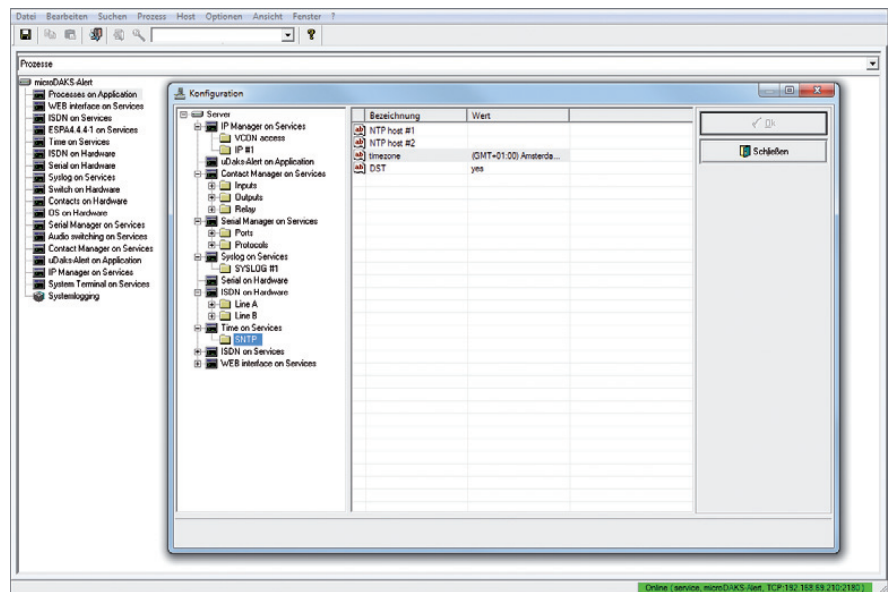

VCON - the service console for OScAR-Eco V4R1

1. only OScAR-Eco 100
2. only OScAR-Eco 200

## Browser-based administration

The administration and user-specific configuration, as well as the retrieval of process protocols is browser-based and in multiple languages (German, English, French, Dutch, Turkish).

This covers:

- Database/server information queries
- Basic settings
- Configuration of individual times or periods of activity
- Definition of display/audio information
- Configuration of base stations (DECT) and access points (WiFi)
- Configuration of medallions (DECT)
- Configuration of OAP alarms (WiFi)
- Configuration of contact inputs
- Configuration of contact outputs
- Configuration of broadcast groups
- Configuration of conferences

- Retrieval of protocols

### Definition of the different broadcast scenarios

When the "Broadcasts" menu item is selected OScAR-Eco shows a list of all configured groups. In this context menu you can add new groups and view or edit and delete existing ones.

For each group you can customize:

- Name, identifier, number of subscribers to reach
- Group-specific info (from: Display/Audio info, see below)
- Either follow-up broadcast(s) or the conference to convene
- Up to 25 targets with individual properties; target type;

time period (see below); security code

- Call excess targets with the same priority level (yes/no)
- Display text in the call state (initiator or group information)
- Contact output to activate
- Broadcast priority, high or low
- Activation code for activation over the phone
- Recording of an ad-hoc announcement possible (yes/no)
- Status info on the initiator who launched the broadcast over the phone (yes/no)
- Ad-hoc specification of the number of subscribers to reach (yes/no)
- Deactivation of the audio signaling to the initiator, also for a possible downstream conference (yes/ no)

- If needed, the conference mode with optional priority-dependent suppression of announcements and limitation of the right to speak
- Dispatch of results protocols as e-mail with transmission condition<sup>1</sup>

## Configuration of conferences

Conferences are convened either as phone-meeting-point by the subscribers calling in or via a broadcast where the reached subscribers are switched together into a conference. Combinations of dial-in and thru-switching are also possible.

For every conference you can customize:

- Description
- Start-ID and entry ID
- Start/entry announcement and announcement played by the system in the call process
- Max. wait time for start (for entry into a conference prior to its activation) and for call
- Max. conference length and the max. inactive time
- Max. number of subscribers allowed to dial into the conference by themselves
- Convert keypad or SIP DTMF signaling to in-band DTMF (yes/no)

## Customization of the display and audio info

All information that is output in the form of text messages or voice announcements is administrated centrally.

This administration includes:

- Specification of the different display and audio information, in

The screenshot shows the 'Basic settings - General' configuration page in the UNIFY OSCAR-Eco200 interface. The left sidebar contains navigation buttons for Database/Server, Basic settings (selected), Times, Display/Audio info, Access Points, Medallions, OAP Alarms, Contact inputs, Contact outputs, Broadcasts, Conferences, and Reports. The main content area is divided into three sections: 'Time/date info' with fields for Time format (12h) and Format of date (MM-DD-YYYY); 'Broadcasts' with fields for Maximum ringing time (30), Interval if no answer (15), Interval if busy (10), and Number of high priority processes (0); and 'Positioning' with checkboxes for DECT and WiFi, and four Name VNS fields.

Basic settings - General

The screenshot shows the 'Broadcasts - Group-specific parameters' configuration page. The left sidebar is identical to the previous screenshot. The main content area is titled 'Edit Broadcast-Group 'Engineers'' and is split into 'Group-specific parameters' and 'Broadcast-Targets'. The 'Group-specific parameters' section includes fields for ID (2000), Name (Engineers), Use Display/Audio info (8001:Elevator Error), Number of Broadcast-Targets to reach (1), Follow-up broadcast if results negative/positive ((none)), Activation code (1122), and various checkboxes for phone activation and recording. The 'Broadcast-Targets' section includes checkboxes for High priority, Show initiator info, Security code required, Also call excess targets, and Contact output. A 'Results e-mail' section at the bottom includes a field for Send e-mail to (Name@company.com) and a dropdown for Sending condition (always).

Broadcasts - Group-specific parameters

The screenshot shows the 'Conferences - Edit Conference 'Emergency Conf.' configuration page. The left sidebar is identical to the previous screenshots. The main content area is titled 'Edit Conference 'Emergency Conf.' and contains fields for Name (Emergency Conf.), Start ID (111), Entry ID (112), Start announcement (8010: ER Conference), Entry announcement (9205: Entry), Dial-up announcement (9206: Dialing), Max. wait time for start (0), Max. wait time for call (120), Max. Conference length (600), Max. inactive time (0), Max. dial-in subscribers (2), and an In-band DTMF to the initiator checkbox.

Conferences

1. only OSCAR-Eco 200

- cluding name, display text, relevant WAV file (max. 15 s per voice announcement) and additional details
- Upload of WAV files and playback of stored announcements
- Recording of announcements over the phone
- Output of status information

## Customization of times and time periods

Definition of specific time periods makes it possible to restrict calling of individual destinations to predefined times, e.g. exclusively to the normal working hours.

In addition, individual contact detectors can be assessed and set off alarms at specific times only, e.g. open doors only at night, or hot water temperature monitors in hotels only early in the morning.

The definition of time periods includes:

- Specification of the start and end time
- Specification of the relevant days of the week
- Special holiday assessment including a fully customizable holiday table

## Definition of the functionality of contact inputs/outputs

For each contact input of OSCAR-Eco you can customize:

- The operating mode for the input
- The broadcast group activated by the contact input and the information that is output
- The ways in which a short circuit or line break detection are signaled

The function of each contact output can be customized:

- Either in combination with a specific broadcast process (specific process active)
- Or as a status output for a system state, e.g. "Red Alert" or "At least 1 short circuit/line break detected".

ID	Name	Display text	Wave file	Last upload	Length	Assignable
9920	GMD 5351	GMD 5351	GMD_5351.wav	30.01.12 16:33	3 s	yes
9906	Residence	Residence	Residence.wav	01.02.12 12:44	2 s	yes
9905	Parking	Parking	Parking.wav	01.02.12 12:43	2 s	yes
9904	Hall 2 Fl Bldg1	Hallway 2.Fl. Building 1	Hall_2.Fl_Bldg1.wav	01.02.12 12:41	3 s	yes
9903	Bldg. 2 Rm. 170	Building 2. Room 170	Building_2.Room_170.wav	01.02.12 12:40	3 s	yes
9902	Printer 2.Floor	Printer Room 2. Floor	Printer_Room_2_Floor.wav	01.02.12 12:38	2 s	yes
9901	Elevator NewBldg	Elevator New Bldg.	Elevator_NewBldg.wav	01.02.12 12:37	2 s	yes
9900	Storage 2. Floor	Storage 2.Floor	Storage_2_Floor.wav	01.02.12 12:36	2 s	yes
9930	Nurse Smith	Alarm from room	AP-Nurse_Smith.wav	23.10.13 15:49	2 s	yes
9800	BC has started	Broadcast has started	E-9800_BC_has_started.wav	05.08.10 19:23	4 s	no
9731	Received AccPnt	Received Access Point	E-9731_DP_Received access	14.06.10 19:32	2 s	no
9721	Not locatable	Not locatable	E-9721_DP_Not locatable for	14.06.10 19:32	3 s	no
9702	Received BaseStn	Received Base Stn.	E-9702_DP_Received base stn	14.06.10 19:30	2 s	no
9400	Funchn not poss.	Sorry, function not possible	E-9400_IT_Apology.wav	14.06.10 19:29	3 s	no
9206	Dialing	Telephone Conference	E-9206_CO_Dialing.wav	07.02.12 11:29	5 s	no
9205	Entry	Telephone Conference	E-9205_CO_Entry.wav	07.02.12 11:28	5 s	no
9204	Entry ID	Entry ID?	E-9204_CO_Entry ID.wav	07.02.12 11:27	7 s	no

Display/Audio info

Name	Days of the week	Start time	End time	On holidays
late shift	Tue, Thu, Fri	8:00	7:00	no
early shift	Mon, Wed, Sat	7:00	12:00	yes

Times - Time segments

Contact outputs



## Registration of base stations and access points

To utilize the positioning function, you must configure the base stations or access points. This includes for every base station and access point:

- Description
- MAC address of the access point or the identifier of the base station
- Assigned display/audio info as positioning results

## Registration of supported end devices/medallions for special alarms

To set off emergency calls and activate alarm processes via OAP protocol - originating from Unify OpenStage WL3 handsets (deliberate and automatic activation) - the broadcast group to be activated and the device-specific or user-individual display/audio info transmitted to all alerted subscribers during the broadcast (e.g. the name of the distressed user) can be configured for each device.

In combination with alarm medallions the broadcast group is not entered as this information is sent by the medallion.

Note: GMD medallions are not supported.

## Retrieval of reports

Via the browser-based user interface, all reports saved on the internal microSD card<sup>1</sup> and the internal CompactFlash card<sup>2</sup> can be displayed, either in a general overview or a detailed view, and report printouts can be initiated.

This also includes the export of saved reports in blocks and internal deletion of reports. This presupposes the user has the relevant authorizations.

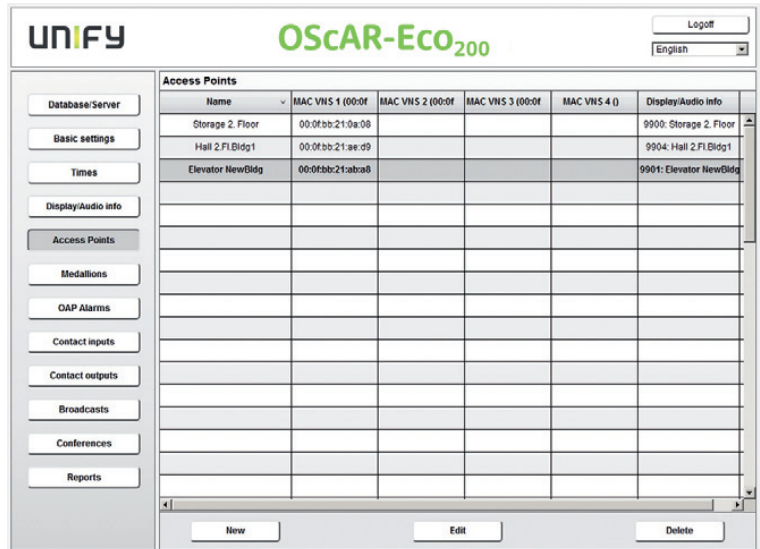

Access Points

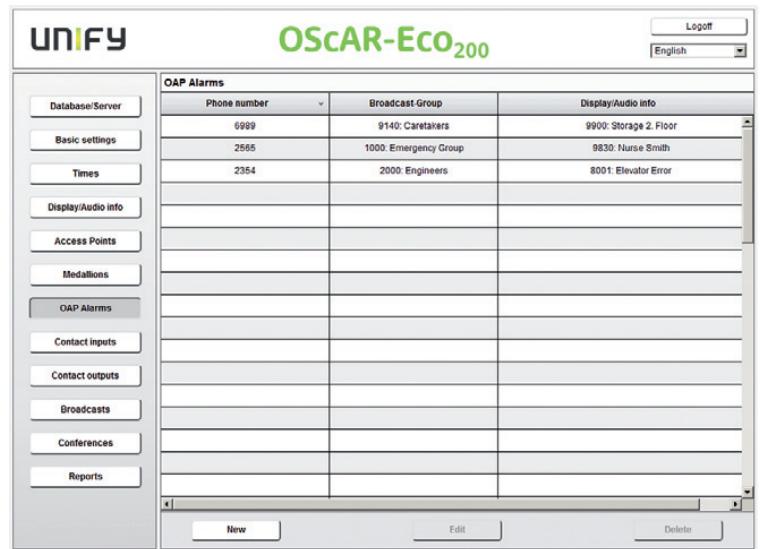

OAP Alarms

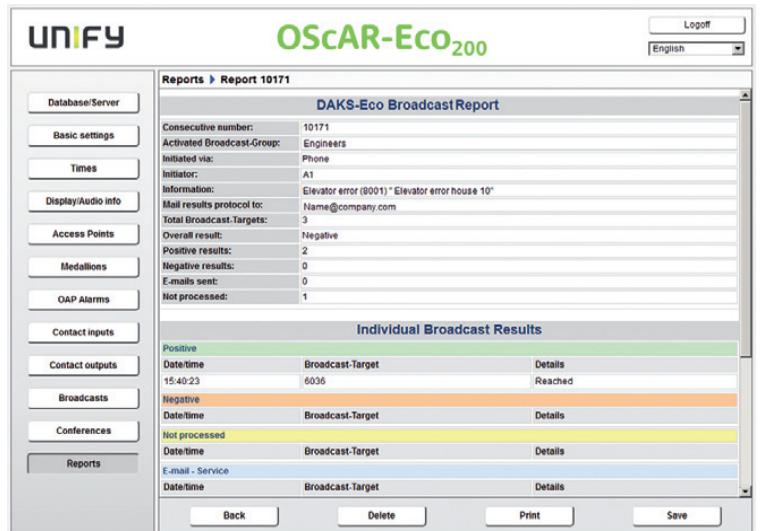

Reports

1. only OSCAR-Eco 100  
2. only OSCAR-Eco 200

# Interfaces and peripheral equipment

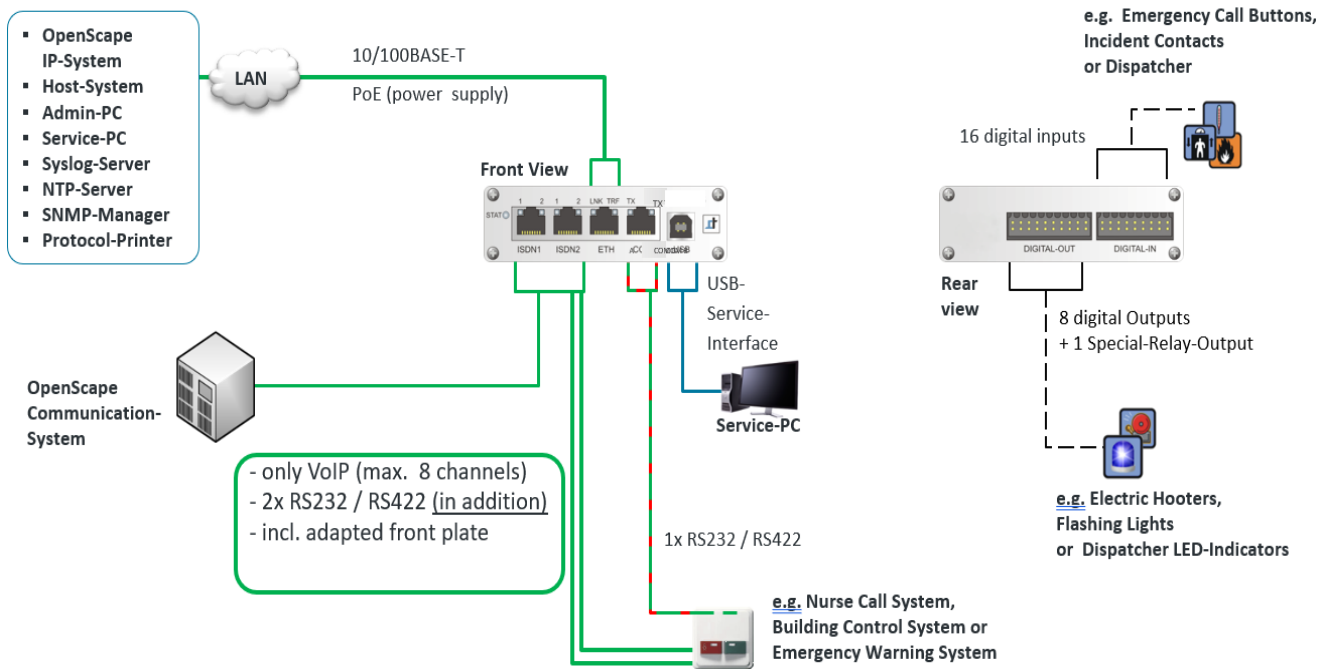

Interfaces and peripheral equipment of OSCAR-Eco 100

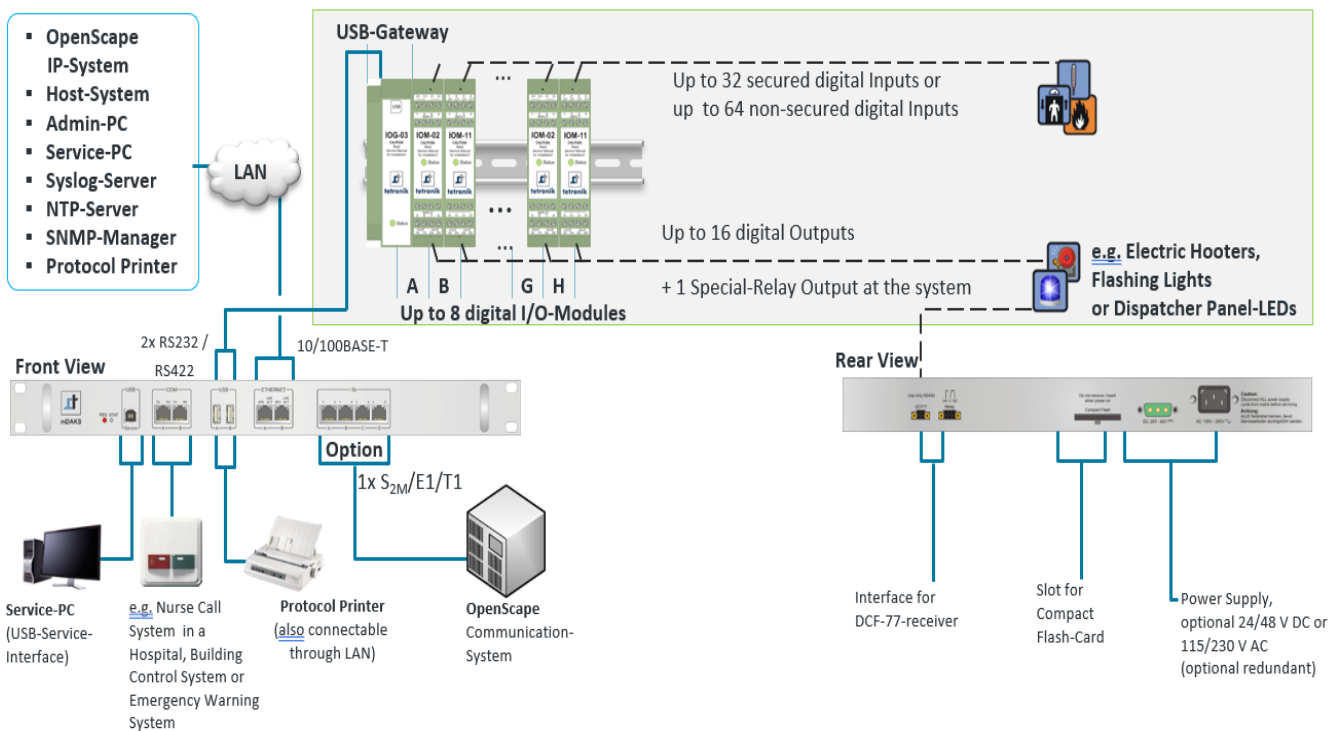

Interfaces and peripheral equipment of OSCAR-Eco 100

# Technical data

## Technical data for OScAR-Eco V4R1

Feature/Properties	OScAR-Eco 100	OScAR-Eco 200
<b>Housing/dimensions</b>	Table-top unit (165 mm x 105 mm x 30 mm)	19" housing (1U) for rack installation
<b>Number of parallel usable telephone channels</b>	4 - 8	4 - 30
<b>PBX connection technology</b>	<ul style="list-style-type: none"> <li>VoIP trunking (encrypted/unencrypted)</li> </ul>	<ul style="list-style-type: none"> <li>VoIP trunking (encrypted/unencrypted)</li> <li>S<sub>2M</sub>/E1/T1 trunking (1 port, only for North America) via plug-in module</li> </ul>
<b>Signaling protocols</b>	QSIG, CorNet-NQ, DSS1, SIP, SIP-Q, NI2	
<b>Speech codecs</b>	G.711, A-law or -law	
<b>PC and operating system(s)</b>	1 computer core with Clinux™ operating system	<ul style="list-style-type: none"> <li>1 computer core with Clinux™ operating system</li> <li>2 computer cores with Linux™ operating system</li> </ul>
<b>Mass storage device for program, data, licenses, reports, and voice announcements</b>	Pluggable microSD card	Pluggable CompactFlash card
<b>LAN interface for VoIP, VCON service access, administration via browser and peripheral interconnectivity via ESPA-X, Syslog, NTP, SNMP, and printer protocol (Raw/Port 9001)</b>	1x 10/100-BASE-T (1 IP address)	2x 10/100BASE-T (2 IP addresses): <ul style="list-style-type: none"> <li>Either one or two LAN connections</li> <li>VoIP separately if wanted</li> </ul>
<b>Serial RS232/RS422 ports (electrically isolated) with protocol ESPA4.4.4/TAP</b>	<ul style="list-style-type: none"> <li>1 port built-in</li> <li>Optionally 2 further ports via plug-in module, alternative to ISDN</li> </ul>	2 ports built-in
<b>USB interface for the system startup</b>	yes	
<b>Protocol printer connection</b>	Via LAN	Either via LAN or USB
<b>Power supply</b>	<ul style="list-style-type: none"> <li>Either via a data switch with Power-over-Ethernet support (PoE Class 2)</li> <li>Or via a PSU looped into the LAN connection (PoE injector) from 100... 240 VAC</li> </ul>	<ul style="list-style-type: none"> <li>Via two separate internal PSUs, either from 24/48 VDC or from 115/230 VAC (for redundancy purposes also in parallel)</li> <li>In combination with an external AC/DC converter, power supply from 2 x 115/230 VAC is also possible</li> </ul>
<b>Power consumption</b>	< 6.5 W (PoE Class 2)	<ul style="list-style-type: none"> <li>with AC: approx. 25 W</li> <li>with DC: approx. 20 W</li> </ul>
<b>Digital I/O</b>	Built into the device: <ul style="list-style-type: none"> <li>1 special relay output with make and break contact, e.g. for last error message</li> <li>8 standard outputs</li> <li>16 contact inputs with short-circuit and line-break detection</li> </ul>	Built into the device: <ul style="list-style-type: none"> <li>1 special relay output with make and break contact, e.g. for last error message</li> </ul> Additionally up to 8 digital I/O modules, detached via USB and matching USB gateway, electively also mixed: <ul style="list-style-type: none"> <li>Either modules with 8 inputs with no short-circuit and line break detection and 2 outputs</li> <li>Or modules with 4 inputs with short-circuit and line-break detection and 2 outputs</li> </ul>

Feature/Properties	OscAR-Eco 100	OscAR-Eco 200
<b>National approvals</b> (country codes pursuant to ISO 3166)	UL, FCC, CE and Australia RCM with the following national approvals: <ul style="list-style-type: none"> <li>All CEN member states: All EU countries, CH, IS, MK, NO, TR</li> <li>All CEN affiliate member states: EG, AL, AM, AZ, BY, BA, GE, IL, JO, LB, LY, MD, ME, MA, RS, TN, UA</li> <li>The following other countries: AU, CA, HK, IN, MY, NZ, RU, US</li> </ul>	

## New features of OscAR-Eco V4R1 vs. V4

Feature or function	OscAR-Eco 100	OscAR-Eco 200
<b>New price model</b>	yes, now with separation of hardware and software/licenses	
<b>Variable number of telephony channels</b>	yes: 4 - 8,	yes: 4 - 30
<b>More cost-efficient entry-level basic equipment</b>	yes, without licenses for ESPA-X sessions, serial interfaces and digital I/O	
<b>Dispatch e-mails and utilize e-mail addresses as broadcast targets, and send results protocol as e-mail to persons in charge</b>	no	Option
<b>Receive and process e-mails (mail-to-phone via ESPA-X)</b>	no	Option
<b>Support of external OscAR Satellite components, each with 1x serial ESPA4.4.4 and 16x digital IN and (8+1)x digital OUT</b>	no	optional, up to 5
<b>Additional serial interfaces RS232/RS422</b>	yes optional, up to 3, only for VoIP	no still 2 (as before), but now as option
<b>Additional ESPA-X interface licenses</b>	same as before 1x Standard ESPA-X, but now available as an option and also simultaneously to serial interfaces	yes optionally up to 5x ESPA-X for: OscAR Satellite, standard ESPA-X and/or mail-to-phone
<b>Additional interfaces with callback function (ESPA4.4.4/ESPA-X)</b>	no as before 1x, but now as option	yes no up to 2x, optional
<b>New licensing of Digital-I/O in packages</b> Note: Secure = with short-circuit and line-break detection	yes each with 16x IN Secure and 8x OUT	yes Electively usable for: <ul style="list-style-type: none"> <li>16x IN Secure and 8x OUT, or</li> <li>32x IN Standard and 8x OUT</li> </ul>
<b>Support of DCF77</b>	no	yes only requires a DCF77 receiver
<b>Support of more broadcast groups than before</b>	yes now 100 (previously 50)	yes 100 in the basic package, max. 1,000 (previously: 100 without expansion options)
<b>Support of more announcements/texts than before (= information)</b>	no same as before max. 200	200 in the basic package, max. 1,000 (previously: 200 without expansion options)
<b>Support of more broadcast targets in one broadcast group</b>	yes now 25 (previously 10)	no same as before 25
<b>Variable expansion option for groups and information</b>	no	yes in packages of 100 each
<b>Show info on current broadcast on handset display (for initiator)</b>	yes	



Feature or function	OScAR-Eco 100	OScAR-Eco 200
Follow-up broadcasts now also possible if broadcast results are positive	yes even if follow-up broadcast was administrated for negative broadcast results	
Various additional features for broadcasting and conferencing	Optionally via add-on feature "Advanced Workflow", including: <ul style="list-style-type: none"> <li>• Broadcasts with ad-hoc announcement and/or variable number of subscribers to reach</li> <li>• Broadcasts with target-individual security code and/or with activation code</li> <li>• Conference mode with priority-dependent suppression of announcements and limitation of the right to speak</li> <li>• Support of time profiles including holiday table for temporary dialing of broadcast targets and evaluation of digital inputs</li> </ul>	
Direct recording of prepared announcements over the phone	yes	
High-priority processes	yes	yes same as before
Support of SNMPv3	yes	

